

Additional References

Other resources are available to assist you in taking better care of your construction site.

Indiana Handbook for Erosion Control in Developing Areas

Provides installation instructions on five of the more commonly used building site erosion and sediment control practices. Available from the Indiana Department of Natural Resources, Customer Service Center, 402 West Washington Street, W-160, Indianapolis, IN 46204, 317/232-4200.

Soil Surveys

Another valuable reference when building a home is your county's detailed soil survey report, which contains information about soil hazards and limitations (*such as wetness*) that may need to be addressed at the time of the construction. Single copies of soil surveys are available at your local Soil and Water Conservation District (SWCD) office or the USDA Natural Resources Conservation Service, 6013 Lakeside Boulevard, Indianapolis, IN 46278-2933, 317/290-3200 or 317/290-3225 FAX.

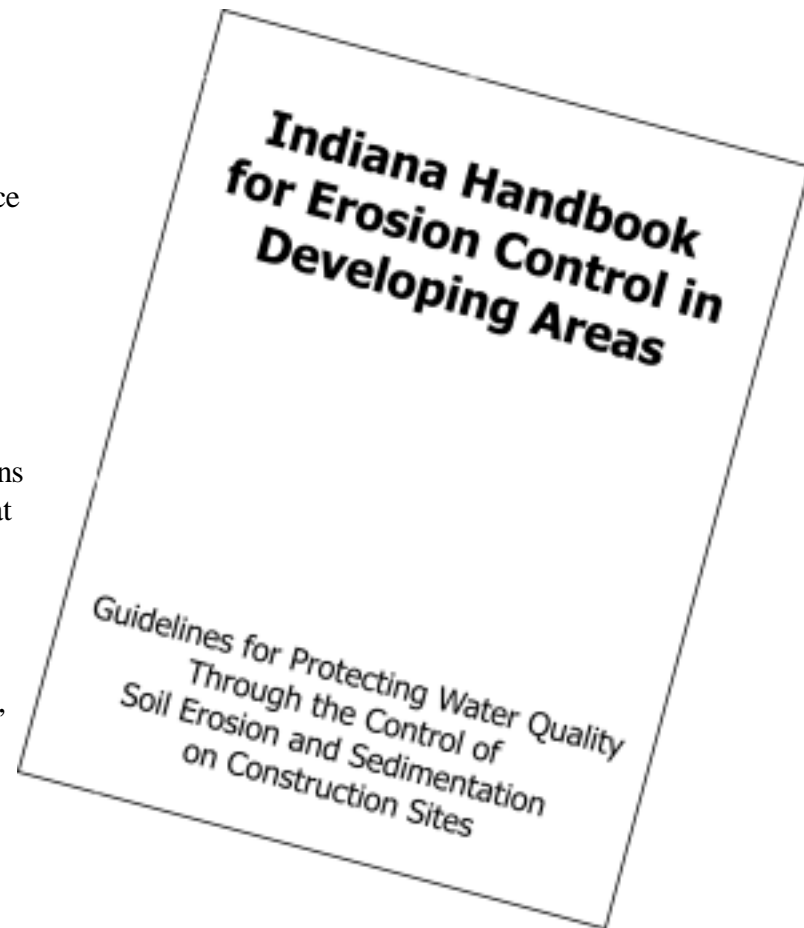

Division of Soil Conservation
Indiana Department of Natural Resources
402 West Washington Street, Room W-265
Indianapolis, IN 46204-2782
317/233-3870
317/233-3882 FAX
www.state.in.us/dnr/soilcons



The Indiana Department of Natural Resources prohibits discrimination on the basis of race, color, national origin, age, sex, or disability. If you believe you have been discriminated against in any program, activity, or facility as described above, or if you desire further information, please write to IDNR Executive Office, 402 West Washington Street, Room W-265, Indianapolis, IN 46204 (317/232-4020).

Revised September 2001

Erosion & Sediment Control for Individual Building Sites

Soil erosion and resulting sedimentation are a leading cause of water quality problems in Indiana. Although erosion has long been associated with agricultural activities, it is also a major concern at construction sites, if the disturbed land is left unprotected. Every phase of a construction project has the potential of contributing significant quantities of sediment-laden runoff. Therefore, as a site is developed, all who are associated with a project must do their part to control erosion.



The developer is the primary entity having responsibility for controlling erosion, sedimentation, and stormwater runoff associated with the overall construction project. He or she is expected to install effective sediment control practices and implement an aggressive seeding program to address erosion and sedimentation. A seeding program can provide a financial benefit to the developer because studies have shown vegetated lots typically have a higher sale potential than un-vegetated lots. One of the main components during the initial phases of construction is the installation of the infrastructure (e.g., roads, utilities, and stormwater management systems). As the infrastructure is installed, it gradually transforms into a very efficient conveyor of stormwater runoff and the associated pollutants. In many communities, developers are expected to use appropriate stormwater management practices that will

reduce the impact of increased runoff associated with the construction project.

This pamphlet addresses erosion and sediment control on an individual building lot, typically one acre or less in size.

The final phase of most projects is the construction that takes place on building sites. As individual lot construction progresses, residents and businesses begin to occupy buildings that have been completed. Sedimentation in roads,

streets, and stormwater drainage systems may now become a nuisance and potential safety hazard to businesses and their clientele as well as residents of the development. The severity of these impacts is often directly related to the intensity of individual lot construction. Once independent construction activities commence on an individual residential or commercial building lot(s), the developer does not necessarily maintain the authority or responsibility to address erosion, sedimentation, and stormwater runoff. Often times these responsibilities are passed onto the individual lot owners and/or their respective contractors.

This pamphlet addresses erosion and sediment control on an individual building lot, typically one acre or less in size. First, it looks at some consequences of construction site erosion and presents four principles important for control. Next, it addresses the issue of proper lot drainage. Then it presents the seven steps within a construction sequence that should result in effective erosion control. Also included are installation instructions for several commonly used building site erosion and sediment control practices, as well as suggested reference materials and sources for further assistance.

Primary Concerns Related to Erosion and Sedimentation

Water Quality

Sediment is the number one pollutant, by volume, of surface waters in the state of Indiana. It impacts water quality by degrading the habitat of aquatic organisms and fish, by decreasing recreational value, and by promoting the growth of nuisance weeds and algae.

Flooding

Sediment accumulation in streams, lakes, and rivers reduces their capacity to contain stormwater, which can result in increased flooding.

Local Taxes

Sediment that finds its way into streets, storm sewers, and ditches results in additional maintenance costs for local, state, and federal governments.

Property Values

Sediment deposits not only impair water quality but also damage property, thus reducing its use and value.



Sample Erosion / Sediment Control Plan

Every building site is unique and poses its own potential erosion hazards. In many instances, additional or alternative control methods are necessary if the lot is adjacent to a creek, lake, or wetland; slopes are greater than six percent; receives runoff from adjacent areas; and/or more than one acre of ground is disturbed.

NOTES:

1. It is the responsibility of the property owner and contractor to comply with State laws and local and county ordinances regarding construction site erosion and sediment control.
2. This plan is only a sample plan and is not intended to be all inclusive or address every situation, additional or modified practices may be required on some sites.
3. Erosion or sediment control measures must be functional and maintained throughout construction.
4. Maintain positive drainage away from the structure(s).

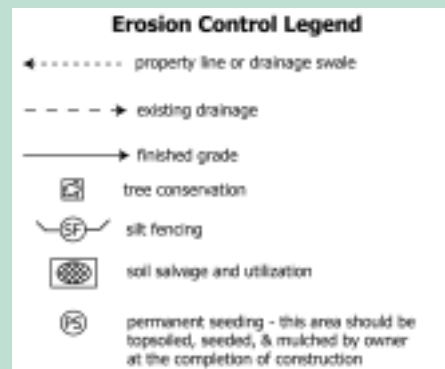
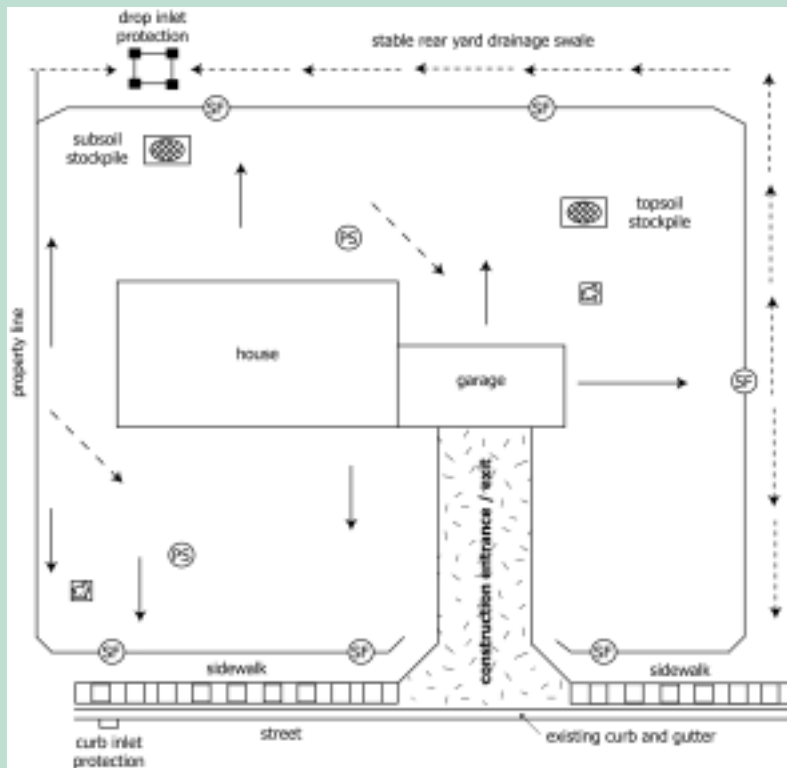

Temporary Downspout Extenders

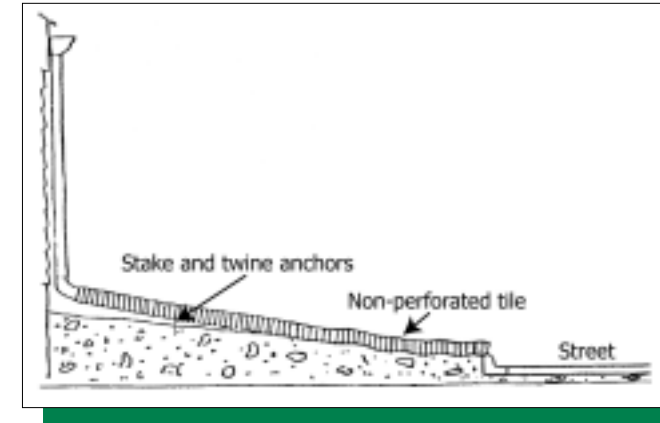

1. Install extenders as soon as gutters and downspouts are installed to prevent erosion from roof runoff.
2. Use non-perforated (un-slotted) drainage tile.
3. Route water to a stable grassed or paved area or to the storm sewer. Do not route water directly to a street or sidewalk in the winter due to the formation of ice.
4. Remove downspout extenders after vegetation is established.

Drop Inlet Protection

1. Construct a six-inch dike on the down slope side to prevent bypass flow.
2. Dig a trench eight inches deep and four inches wide.
3. Space support posts evenly against the inlet perimeter a maximum of four feet apart, and drive them about 1.5-feet into the ground.
4. Cut enough filter fabric from a single roll to eliminate joints.
5. Using lath and nails, fasten the fabric to the posts.
6. Place 12-inches of fabric in the trench, extending the bottom four inches toward the upslope side.
7. Join silt fence sections by using a wrap joint.
8. Backfill trench with soil materials and compact.
9. Cross brace the corners to prevent collapse.
10. Inspect at least weekly and after each storm event, and repair as needed, and remove accumulated sediments after every storm.

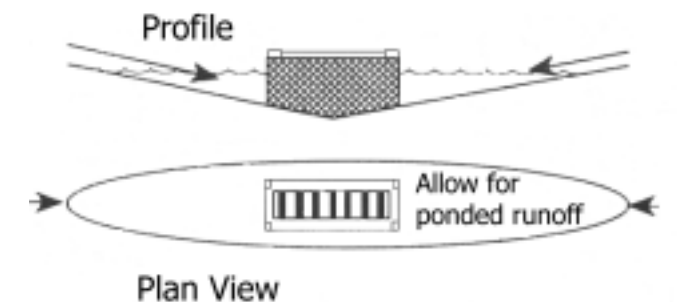
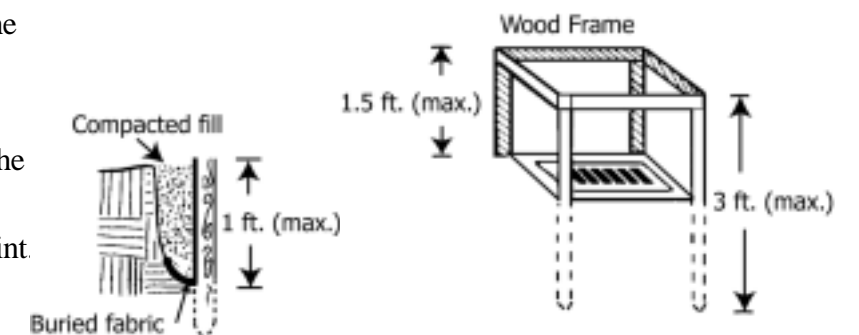

Note: Either follow the directions above, or utilize a pre-manufactured drop inlet protection device. These products are available commercially in a wide variety of materials and designs.

Erosion & Sediment Control Practices

Silt Fences

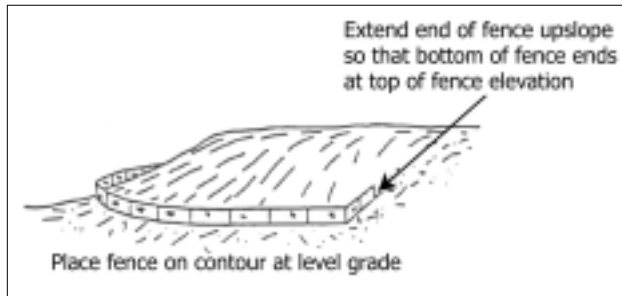

1. Install silt fence parallel to the contour of the land.
2. Extend ends upslope to allow water to pond behind fence.
3. Excavate a trench 4-inches wide, 8-inches deep.
4. Install fence with posts on the down slope side.
5. Place 12-inches of fabric in the trench, extending the bottom four inches toward the upslope side.
6. Join silt fence sections by using a wrap joint.

7. Backfill trench with soil materials and compact.
8. Inspect at least weekly and after each storm event, repairing as needed and removing sediment deposits when they reach one-half the fence height.

Note: Silt fence has a life expectancy of six months to one year, whereas straw bale barriers have a limited life of three months or less.

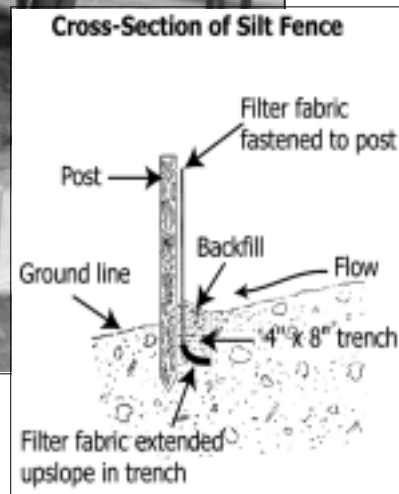
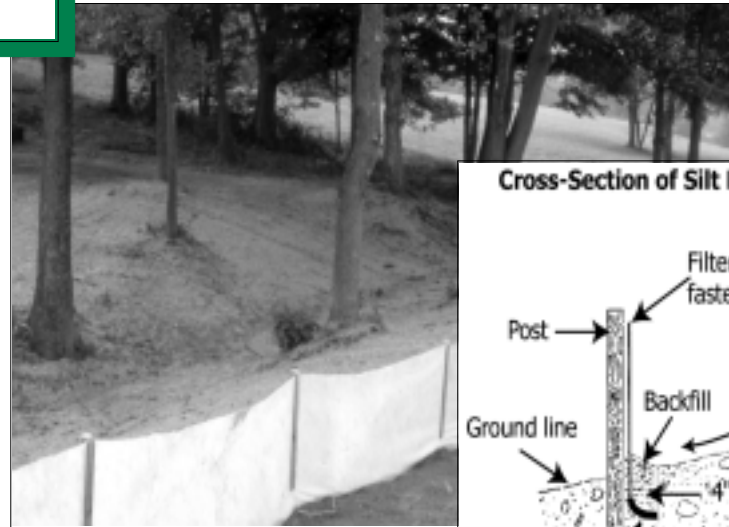

Gravel Construction Entrances

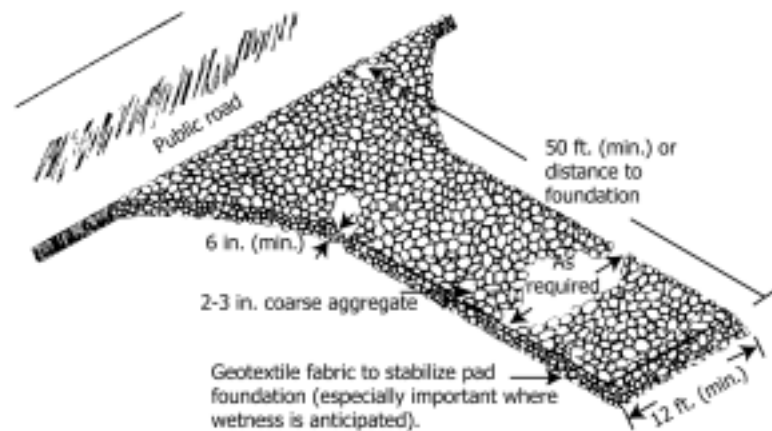

1. Place six inches of coarse aggregate (INDOT CA No. 2) over a stable subgrade.
2. Construct the drive at least 12-foot wide and 50-foot long or the distance to the foundation.
3. Add stone as needed to maintain six inches of clean depth.
4. To improve stability or if wet conditions are anticipated, place geotextile fabric on the graded foundation.



Controlling Building Site Erosion & Sedimentation

Erosion control is important on any building site regardless of its size. Usually, principles and methods for controlling erosion and reducing off-site sedimentation are relatively simple and inexpensive. Here are four basic steps to follow when developing a building site.

Evaluate the Site

Inventory and evaluate the resources on the lot before building. Location of structures should be based on the lot's natural features. Identify trees that you want to save and vegetation that will remain during construction. Also identify areas where you want to limit construction traffic. Wherever

possible, preserve existing vegetation to help control erosion and off-site sedimentation.

Select & Install Initial Erosion/Sediment Control Practices

Determine the specific practices needed, and install them before clearing the site. Among the more commonly used practices are vegetative filter strips, silt fences, gravel drives, and inlet protection.

Develop a Practice Maintenance Program

Maintenance of all practices is essential for them to function properly. Practices should be

inspected twice a week and after each rainfall event. When a problem is identified, repair or replace the practice immediately. If frequent repairs are required, another more substantial practice may need to be selected. In addition, any sediment that is tracked onto the street should be scraped and deposited in a protected area. Do not flush sediment from the street with water.

Revegetate the Site

Establish vegetation as soon as possible. A well-maintained lot has a higher sale potential.

Building Lot Drainage

The best time to provide for adequate lot drainage is before construction begins. With proper planning, most drainage problems can be avoided. That's important because correcting a problem after it occurs is usually much more difficult and costly. Here's what it takes to ensure good lot surface and subsurface drainage.

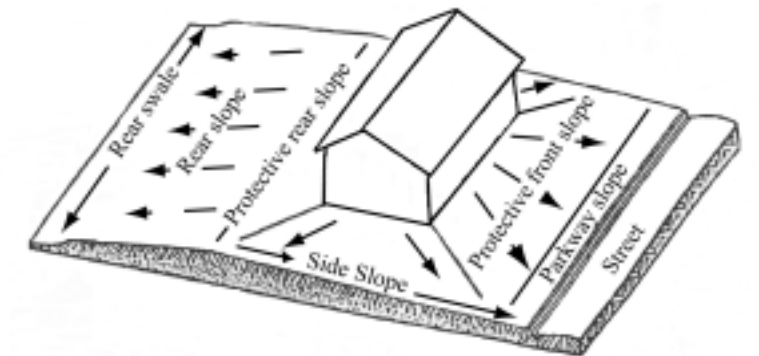

Surface Drainage

- Position the structure a minimum of 18 inches above street level.
- Divert stormwater runoff away from the structure by grading the lawn to provide at least six inches of vertical fall in the first ten feet of horizontal distance.
- Construct side and rear yard swales to take surface water away from the structure.
- Avoid filling in existing drainage channels and roadside ditches, since that could result in wetness problems on someone else's property and/or damage to adjacent road surfaces.

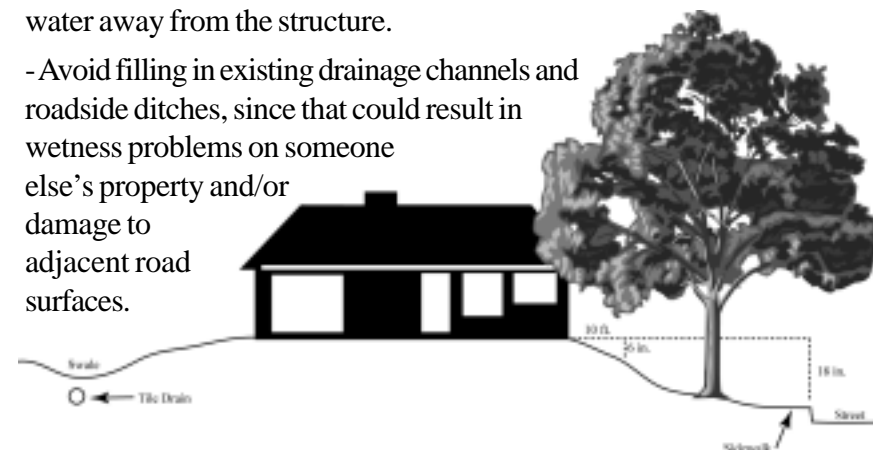

Subsurface Drainage

- Provide an outlet for foundation or footer drains and for general lot drainage by using storm sewers (*where allowed*), or obtain drainage easements if you must cross adjoining properties.
- If you accidentally cut through an existing field tile, assume that it carries water even if currently dry; therefore, reroute (*using the same size tile*) around the structure or septic field, then reconnect it.

Construction Sequence for Erosion & Sediment Control

1 Evaluate the Site

Before construction, evaluate the site; mark vegetative areas and trees to be protected, unique areas to preserve, on-site septic system absorption fields, and vegetation suitable for filter strips, especially in perimeter areas.

Identify Vegetation to be Saved

Select and identify the trees, shrubs and other vegetation to be saved (*see Step 2: "Vegetative Filter Strips"*).

Protect Trees & Sensitive Areas

- ◆ To prevent root damage, do not grade, burn, place soil piles, or park vehicles near trees or in areas marked for preservation.
- ◆ Place plastic mesh or snow fence barriers around the trees' driplines to protect the area below their branches.
- ◆ Place a physical barrier, such as plastic fencing, around the area designated for a septic system absorption field (*if applicable*).



2 Install Perimeter Erosion and Sediment Controls

Identify the areas where sediment-laden runoff could leave the construction site, and install perimeter controls to minimize the potential for off-site sedimentation. It's important that perimeter controls are in place before any earth-moving activities begin.

Protect Down-Slope Areas with Vegetative Filter Strips

◆ On slopes of less than six percent, preserve a 20-to 30-foot wide (minimum) vegetative buffer strip around the perimeter of the property, and use it as a filter strip for trapping sediment.

◆ Do not mow filter strip vegetation shorter than four inches.

Protect Down-Slope Areas with Silt Fences and Other Appropriate Practices

◆ Use silt fencing along the perimeter of the lot's downslope side(s) to trap sediment. *Refer to silt fences practices.*

Install Gravel Drive

◆ Restrict all lot access to this drive to prevent vehicles from tracking mud onto roadways. *Refer to gravel construction entrances.*

Protect Storm Sewer Inlets

Curb inlet protection devices are not efficient in removing sediment from stormwater runoff. Additional erosion and sediment control measures must be incorporated into the plan and the day-to-day construction operations to minimize the amount of sediment entering a street. The best defense in controlling sedimentation is the installation of perimeter protection downslope of the construction activity using gravel construction entrances and daily cleaning and removal of sediment from streets. Even with these measures implemented, sediment and tracked soil will find their way into the street. *"The Indiana Handbook for Erosion Control in*

Developing Areas" contains standards and specifications for several curb inlet protection devices and there are a number of commercial curb inlet protection devices on the market that are designed to capture sediment. However, these practices are not designed to trap large amounts of sediment and require frequent maintenance if they are to remain effective. When selecting a curb inlet protection measure, it is important to select a device that does not block the inlet entirely. Total obstruction of the inlet will cause excessive ponding and in some situations bypass flow that may result in erosion.

◆ Protect on-site storm sewer drop inlets with silt fence material, straw bales, or equivalent measures. *Refer to drop inlet protection diagram.*

3 Prepare the Site for Construction

Prepare the site for construction and for installation of utilities. Make sure all contractors (*especially the excavating contractor*) are aware of areas to be protected.

Salvage and Stockpile Topsoil or Subsoil

◆ Remove topsoil (*typically the upper four to six inches of the soil material*) and stockpile.

◆ Remove subsoil, including any excavated material associated with basement construction, and stockpile separately from the topsoil.

◆ On small building sites, it may not be feasible to stockpile soil material on each individual lot due to space limitations. In these situations, soil material should be transported to

protected areas designated on the overall construction plan or those areas designated by the developer.

◆ Locate the stockpiles away from any downslope street, driveway, stream, lake, wetland, ditch or drainage way.

◆ Immediately after stockpiling, temporary seed the stockpiles with annual rye or winter wheat and/or install sediment barriers around the perimeter of the piles.



4 Build Structure(s) and Install Utilities

Construct the home and install the utilities; also install the sewage disposal system and drill water well (*if applicable*); then consider the following:

Install Downspout Extenders

◆ Although not required, downspout extenders are highly recommended as a means of preventing lot erosion from roof runoff.

◆ Add the extenders as soon as the gutters and downspouts are installed.

◆ Be sure the extenders have a stable outlet, such as a paved area, or a well vegetated area. Do not route runoff directly to a street in winter due to the formation of ice. *Refer to temporary downspout extenders diagram.*

5 Maintain Control Practices

Maintain all erosion and sediment control practices until construction is completed and the lot is stabilized.

◆ Inspect the control practices a minimum of twice a week and after each storm event, making any needed repairs immediately.

◆ Toward the end of the each work day, sweep or scrape up any soil tracked onto roadway(s). Do not flush areas with water.

6 Revegetate Building Site

Immediately after all outside construction activities are completed, stabilize the lot with sod, seed, and/or mulch.

Redistribute the Stockpiled Subsoil and Topsoil

◆ Spread the stockpiled subsoil to rough grade.

◆ Spread the stockpiled topsoil to a depth of four to six inches over rough-graded areas.

◆ Fertilize and lime according to soil test results or recommendations of a seed supplier or a professional landscaping contractor.

Seed or Sod Bare Areas

◆ Contact local seed suppliers or professional landscaping contractors for recommended seeding mixtures and rates.

◆ Follow recommendations of a professional landscaping contractor for installation of sod.



◆ Water newly seeded or sodded areas every day or two to keep the soil moist. Less watering is needed once grass is two inches tall.

Mulch Newly Seeded Areas

◆ Spread straw mulch on newly seeded areas, using one and one-half to two bales of straw per 1,000 square feet.

◆ On flat or gently sloping land, anchor the mulch by crimping it two to four inches into the soil. On steep slopes, anchor the mulch with netting or tackifiers. An alternative to anchored mulch would be the use of erosion control blankets.

7 Remove Remaining Temporary Control Measures

Once the sod and/or vegetation is well established, remove any remaining temporary erosion and sediment control practices, such as:

◆ Remove downspout extenders. Or, shorten to outlet on an established vegetated area, allowing for maximum filtration.

◆ Remove storm sewer inlet protection measures.